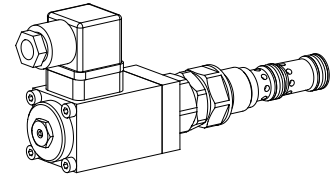

Pressure reducing valve, electric operation
Screw-in cartridge

- Pilot operated
- $Q_{max} = 80 \text{ l/min}$
- $p_{max} = 400 \text{ bar}$
- $p_{N \text{ red max}} = 350 \text{ bar}$

M22x1,5
 ISO 7789

DESCRIPTION

Pilot-operated 3-way pressure reducing valve with mechanical pressure adjustment and electrical pressure changeover. In Version E, with the solenoid switched on, the reduced pressure set is produced. Screw-in cartridge with M22x1.5 thread and cavity in accordance with ISO 7789. As standard version, three nominal pressure ranges are available: 63, 16 und 350 bar. The solenoid for the pressure changeover with a reduced electric power (18 W) corresponds to the VDE-standard 0580. It can be steplessly rotated around its longitudinal axis and correspondingly fixed. The cartridge body is zinc-coated and as a result rust protected.

Attention: Standard normal solenoids with 22 W power must not be utilised.

FUNCTION

The spool in the pilot-operated main part is kept in the basic position by a spring. The connection to the consumer is completely open. The reduced pressure can be adjusted at the pilot control, which is designed as a pressure relief. It opens, when the set value has been reached. As a result, a control volume flow passes through the nozzle in the spool. The resulting pressure difference moves the spool against the spring, the volume flow at the valve inlet is throttled by this, and the reduced pressure is controlled. If forces on the consumer make the reduced pressure rise to above the set value, the spool is displaced to such an extent, that the valve inlet closes and the reduced pressure opens to the tank. The pressure increase is therefore limited. With respect to the hydraulic characteristic values, the device is identical with the pilot operated pressure reducing valve MV.PM22 (2.2-530).

APPLICATION

Pressure control valves are utilised for keeping the pressure in a consumer constant independent of the pressure fluctuations on the supply side. In the case of several consumers, with the pressure reducing valve, the pressure of the individual consumers can be individually adjusted. The integrated pressure relief renders an additional relief valve in the consumer line superfluous. Installation of the screw-in cartridge in control blocks as well as in the Wandfluh sandwich plates (vertical stacked systems) and flange valves of the NG4-Mini, NG6 and NG10 types. (Please note the separate data sheets in register 2.2). Cavity tools are available for machining the cavities in steel and aluminium (hire or purchase). Please refer to the data sheets in register 2.13.

TYPE CODE

	M	V	E	PM22	-		-		#	
Pressure reducing valve										
Pilot operated										
Electric operation: energised solenoid corresponds to set pressure										
Screw-in cartridge M22x1,5										
Nominal pressure range $p_{N \text{ red}}$						63 bar		<input type="text" value="63"/>		
						160 bar		<input type="text" value="160"/>		
						350 bar		<input type="text" value="350"/>		
Nominal voltage U_N / Nominal power P_N										
12VDC / 18W							<input type="text" value="G12"/>			
24VDC / 18W							<input type="text" value="G24"/>			
						110VAC / 18W		<input type="text" value="R110"/>		
						115VAC / 18W		<input type="text" value="R115"/>		
						230VAC / 18W		<input type="text" value="R230"/>		
Design-Index (Subject to change)										

GENERAL SPECIFICATIONS

Denomination	Pilot operated pressure relief valve solenoid operated
Construction	Screw-in cartridge for cavity acc. to ISO 7789
Mounting	Screw-in thread M22x1,5
Mounting position	any
Ambient temperature	-20...+50 °C
Weight	m = 0,78 kg
Fastening torque	$M_D = 50 \text{ Nm}$ for cartridge $M_D = 2,6 \text{ Nm}$ (Qual. 8.8) for fastening screws of solenoid

HYDRAULIC SPECIFICATIONS

Fluid	Mineral oil, other fluid on request
Contamination efficiency	ISO 4406:1999, class 18/16/13 (Required filtration grade $\beta_{6...10} \geq 75$) refer to data sheet 1.0-50/2
Viscosity range	12 mm ² /s...320 mm ² /s
Fluid temperature	-20...+70 °C
Peak pressure	$p_{max} = 400 \text{ bar}$
Nominal pressure ranges	$p_{N \text{ red}} = 63 \text{ bar}, 160 \text{ bar und } 350 \text{ bar}$
Volume flow	$Q = 0...80 \text{ l/min}$
Pilot- and leakage volume flow	see characteristics

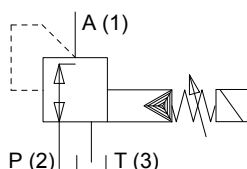
SYMBOL

ELECTRICAL OPERATIONS

Design	Solenoid, wet pin push type, pressure tight
Nominal voltage	$U_N = 12 \text{ VDC}, 24 \text{ VDC}$ $U_N = 110 \text{ VAC}^*, 115 \text{ VAC}^*, 230 \text{ VAC}^*$ AC = 50 to 60 Hz * Connector plug with integrated rectifier
Voltage tolerance	$\pm 10\%$ of nominal voltage
Protection class	IP 65 according to EN 60 529
Relative duty factor	100% ED (see data sheet 1.1-430)
Switching cycles	15'000/h
Operating life (number of switching cycles)	10^7

Connection/Power supply	Over device plug connection EN 175301-803 (DIN 43650) ISO 4400 (2 P+E), construction type A, other connections on request
Solenoid type:	- Medium SIN35V (data sheet 1.1-105)

OPERATING PRESSURE

The desired operating pressure is set by means of a knob and is only reached with the solenoid activated.

Pressure adjustment:

Actuation stroke	$S_b = 2,5 \text{ mm}$
Actuation angle	$\alpha_b = 1080^\circ$ (3 revolutions)

CHARACTERISTICS oil viscosity $\nu = 30 \text{ mm}^2/\text{s}$

$p_{\text{red}} = f(Q)$ Pressure volume flow characteristics
(Maximal adjustable pressure)

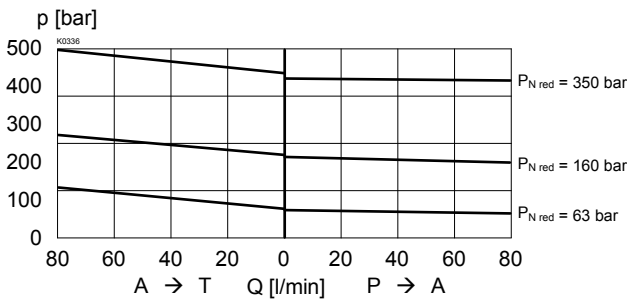

$p_{\text{red}} = f(n)$ Pressure adjustment characteristics
[at $Q = 0 \text{ l/min}$ (static)]

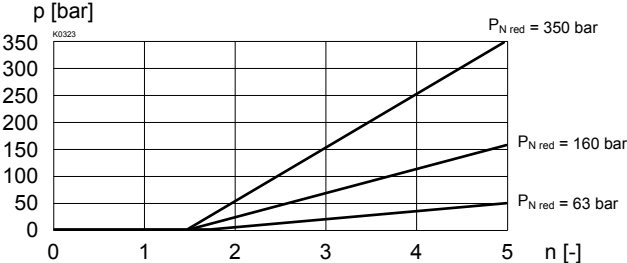

$p_{\text{red}} = f(Q)$ Pressure volume flow characteristics
(Minimal adjustable pressure)

* Consumption resistance dependent on system

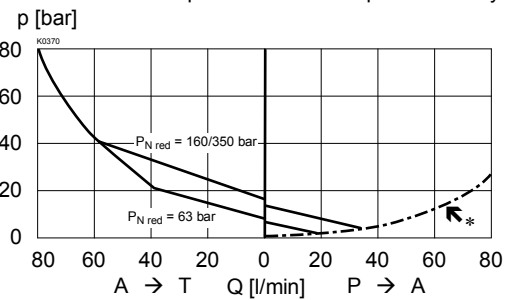

$Q_{\text{st}+L} = f(p)$ Pilot- and leakage volume flow characteristics
[A (1) \rightarrow T (3)]
(Pressure in P (2) = 350 bar)

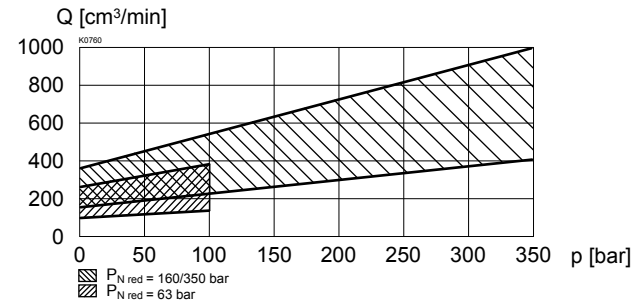
SECTIONAL DRAWING/PRESSURE ADJUSTMENT

For detailed cavity drawing ISO 7789-22-04-0-98 and cavity tools see data sheet 2.13-1004

The reduced pressure can only be adjusted with the solenoid activated.

- 1) Loose lock nut **A**
- 2) Turn knob **B** and solenoid until required system pressure is adjusted
- 3) Fix turning knob **B** with lock nut **A**
- 4) Loose screws **C** slightly, turn solenoid into required position.
(Attention: Solenoid stays under tank pressure.)
- 5) Tighten screws **C** with torque (M_b 2,8 Nm)

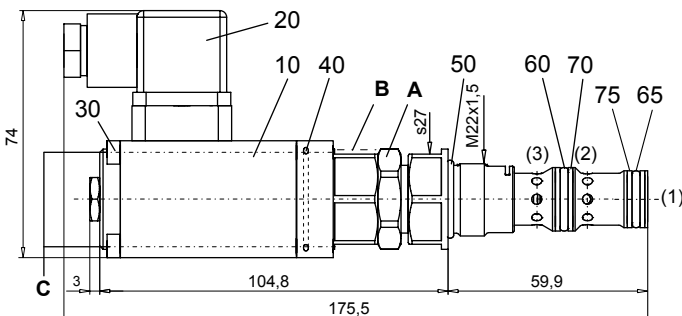
PARTS LIST

Position	Article	Description
10	260.4...	Solenoid SIN35V-...-L18
20	219.2002	Plug (black)
30	249.1007	Socket head cap screw M4x63
40	160.2283	O-ring ID 28,3x1,78
50	160.2188	O-ring ID 18,77x1,78
60	160.2156	O-ring ID 15,60x1,78
65	160.2140	O-ring ID 14,00x1,78
70	049.3196	Back-up ring RD 16,1x19x1,4
75	049.3176	Back-up ring RD 14,1x17x1,4

ACCESSORIES

Flange-/sandwich plate NG4-Mini	Data sheet 2.2-620
Flange-/sandwich plate NG6	Data sheet 2.2-640
Flange-/sandwich plate NG10	Data sheet 2.2-660
Line mount body	Data sheet 2.9-210

Technical explanation see data sheet 1.0-100