

**Proportional solenoid PI29V  
to VDE 0580  
Plug plate to ISO 4400 / DIN 43650  
Protection class IP65**

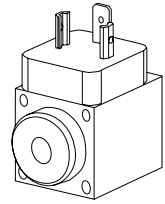

**DESCRIPTION**

The PI29V is a proportional solenoid. Its design corresponds to VDE standard 0580. The steel housing is zinc coated as a standard. Static pressure tightness is 350 bars. All o-rings are Viton. The solenoids are fixed to the valve with four screws. Depending on the intended use, the solenoid can be supplied with a plug screw, or with integrated manual override. The connector plate corresponds to ISO 4400 and DIN 43650.

**FUNCTION**

The horizontal force-stroke characteristics in the working stroke range means that:

- a more or less linear force absorption can be achieved with constant stroke and increasing current absorption;
- a more or less linear stroke variation can be achieved when working against a spring and with increasing current absorption.

This ensures that the reference voltage is adequate at the specified reference temperature to reach the limit current in every case.

**APPLICATION**

Essential for hydraulic proportional-way-, pressure- and current valves. Because of the risk of overheating, the solenoid must never be used separately. The length of the fixing screws depends on the base material of the body. An o-ring is used for the valve seal. Information on screws and o-rings will be found in the data sheets relating to the valves concerned. Before changing the plug screw or the screw with integrated manual override, care must be taken to ensure that the solenoid is not under pressure. Risk of injury! The maximum operating pressure is determined by the valve actually used.

**TYPE CODE**

			PI 29	V	-		-		#	
Proportional solenoid										
Industrial execution										
Square 29 mm housing										
Solenoid completely potted										
Nominal voltage $U_N$		12 VDC								
		24 VDC								
										G12
										G24
with mounted screw plug (data sheet 1.1-300)										HB0
with mounted manual override (data sheet 1.1-300)										HB4,5
Design-Index (Subject to change)										

**DIMENSIONS**

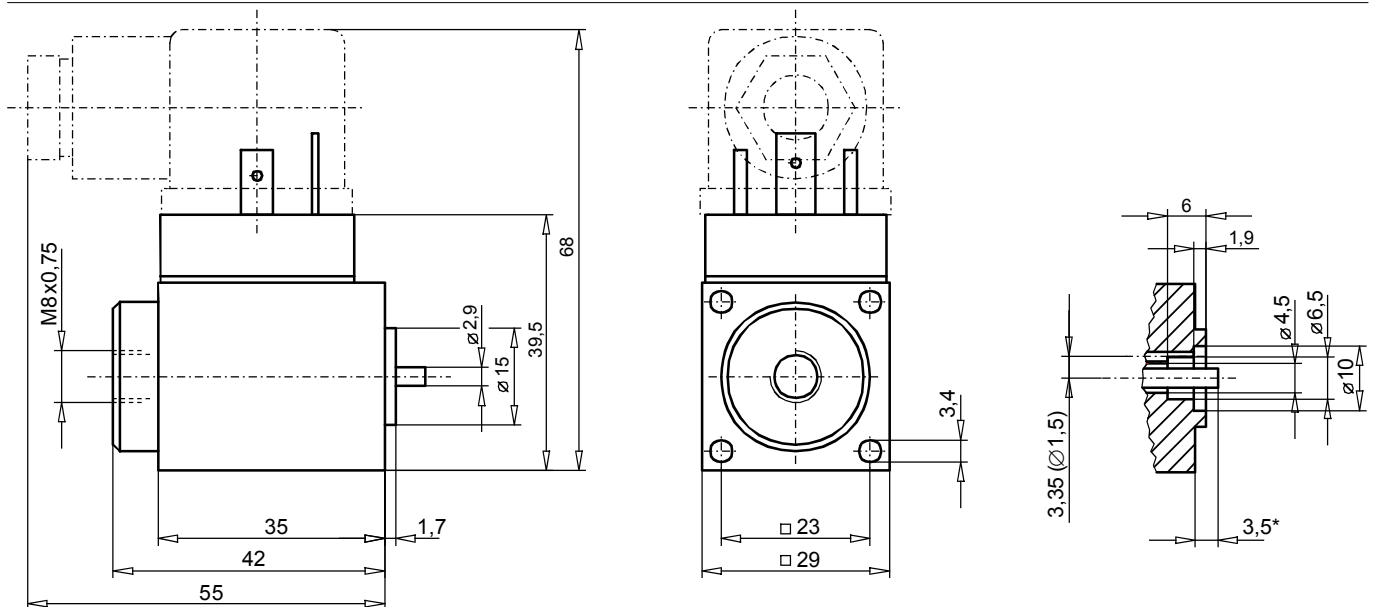

\* Solenoid energised (s = 0 mm)

**CHARACTERISTICS**

Static pressure tightness	350 bar (seal diameter of valve max. 15 mm)
Coil winding insulation class	H
Connection/Power supply	Over device plug connection to ISO 4400/DIN 43650, (2P+E), other connections on request
Protection class EN 60 529	IP65
Relative duty factor	100 %
Reference temperature	50 °C
Seal	Viton, other on request
Fluid	Mineral oil, other fluid on request
Mounting screws	4 x M3 (Quality 8.8)
Housing	Zinc coated steel housing, other surface treatments on request

		12VDC	24VDC
Totale stroke	(mm)	2,5	2,5
Working stroke	(mm)	1	1
Rated force	(N)	29	29
Hysteresis of rated force	(%)	5,5	5,5
Hysteresis of rated current	(%)	5,5	5,5
Nom. linearity deviation	(%)	4,5	4,5
Rated resistance	(Ω)	7,2	31
Rated current	(A)	1,08	0,54
Limiting current	(A)	1,08	0,54
Linearity current	(A)	0,2	0,1
Actuation current	(A)	0,02	0,01
Nominal wattage	(W)	8,1	8,8
Performance limit	(W)	13	13
Number of windings	(-)	645	1'310
Inductivity	(mH)	12	45
Armature weight	(kg)	0,014	0,014
Solenoid weight	(kg)	0,21	0,21

**PERFORMANCE**

F = f (s) Force-stroke characteristics

F = f (I) Force-current characteristics

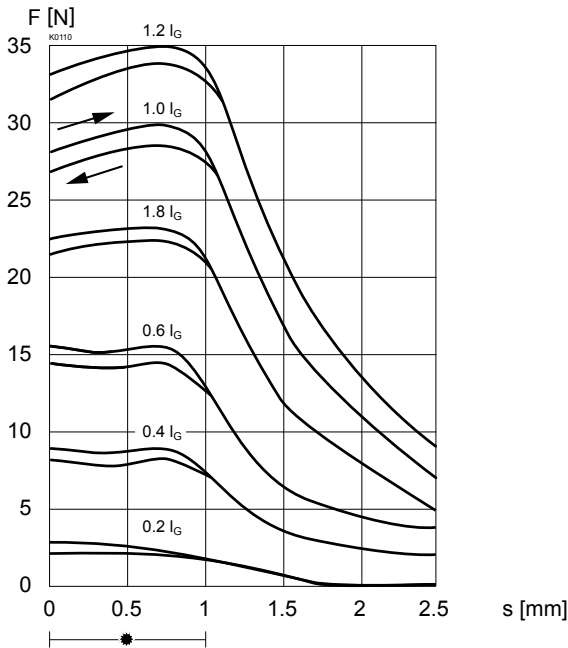

\* = Working stroke

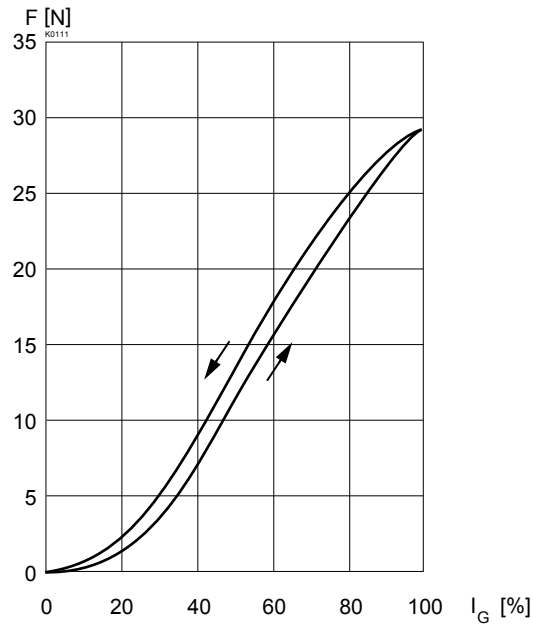
**ACCESSOIRES**

Plug HB0	Article No. 239.2033 data sheet 1.1-300
Plug with integrated manual override HB4,5	Article No. 253.8000 data sheet 1.1-300
Plug grey	Article No. 219.2001
Plug black	Article No. 219.2002

Technical explanation see data sheet 1.1-410