

*Quality products for
demanding use*



WANDFLUH SYSTEMS

“ We want to provide our clients around the world with high-quality products and get engaged as a valued partner in the development of technically demanding hydraulic systems. ”

————— Hansruedi Wandfluh and Matthias Wandfluh —————

ABOUT US

Since 1946, Wandfluh provides and develops high-quality products tailored to various markets. Apart from the standard products, Wandfluh also offers valve and system solutions specifically developed and produced according to particular customer needs.

WANDFLUH GROUP



WANDFLUH AG

Frutigen / CH



WANDFLUH OF AMERICA, INC.

Mundelein / USA



WANDFLUH GMBH

Emmingen / D



WANDFLUH UK LTD

Southam / UK



WANDFLUH SARL

Saint-Priest / F



WANDFLUH CO. LTD

Shanghai / CN



WANDFLUH GMBH

Dornbirn / A



WANDFLUH PRODUKTIONS AG

Frutigen / CH

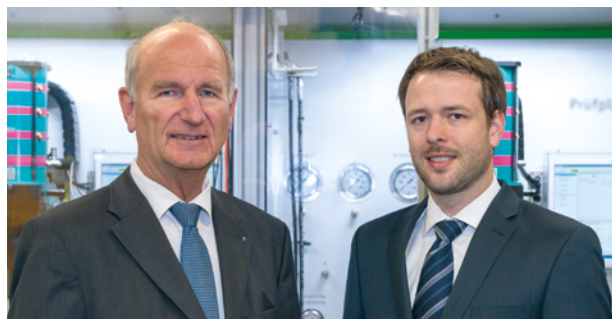

Hansruedi Wandfluh (President, Wandfluh Holding AG) and Dr. Matthias Wandfluh (CEO)

WORLDWIDE

- Own companies in Europe, North America and Asia
- Distributors in over 30 countries around the world
- Flexible and solution-oriented handling of customer needs
- High-quality, cost-effective and punctual processing of projects

PARTNER

- A partner for demanding hydraulic projects due to technical specialists in every field
- Efficient processing of projects from planning to maintenance
- A partner for customer-specific adaptations

KEY POINTS

- High level of in-house production
- Swiss manufacturer
- Quality products and services
- Fast delivery times from prototype to series production
- ISO 9001 certified, since 1992 documented quality
- ISO 14001 for the responsible handling of our resources
- OHSAS 18001 for the protection and safety of our staff

WANDFLUH INDUSTRY

Industry applications have always been geared towards precision, efficiency and reliability. With Industry 4.0, these terms are now becoming even more prominent. Although other techniques and procedures are being implemented to some extent, hydraulics continues to play an important role in fast and powerful motion sequences and clamping devices on processing machines. Stable performance coupled with a high level of repeatability are an indispensable part of this.

FOCUS

Industrial production is in transformation. Industry 4.0 will change the production environment in future and thus also the requirements of hydraulic systems developed for industry. The needs for valve and electronic components will significantly increase. These needs range from redundant switching position monitoring through to customer-specific constructions.

However, one of the industry's key objectives is to develop a precise type of hydraulics that can be adapted to different machinery and has sensitive control characteristics. This can be achieved successfully with intelligent electronics and the corresponding software and guarantees precise and dynamic motion sequences in an industrial production facility.

APPLICATION EXAMPLES

- Axes positioning in machine tools
- Industrial robots
- Cutting feed control with positioning
- Variable workpiece clamping
- Controlled force transmission in cutting installations
- Hydraulic support
- Tension control of coiling machines
- Actuation and control of presses and bending machines

...designed to ensure **reproducibility** and **precision**



INDUSTRY

CHARACTERISTICS

- Precise adaptation to a hydraulic system by means of electronics developed in-house and intelligent software
- Valve technology with switching position monitoring
- High power density (up to 450 bar / 1600 l/min)
- Compact constructions (NG3-Mini, NG4-Mini)
- High precision
- Good repeatability
- Sensitive control characteristics
- Ease of maintenance
- Individual customer-specific adaptations
- Worldwide customer service



WANDFLUH MOBILE

High power density and reliability in all weather conditions have always been important requirements for the use in the mobile sector. In order to carry out heavy work with large machinery efficiently and yet also precisely, hydraulics that are well-adapted to the machinery are required. Precise proportional technology with the corresponding electronics and software are the key to success here.

FOCUS

Components for the mobile sector meet a broad spectrum of requirements. In addition to being suitable for all weather conditions, they must have a high power density and show a high robustness against external influences. Depending on the requirements, explosion protection and/or corrosion protection executions of the valves are also available. The quality of the valves and electronics generally becomes apparent once they are used on a daily basis in mobile devices and machinery, where shocks, vibrations and sharp temperature fluctuations are a part of everyday operations. The focus at Wandfluh is on these factors, when developing valves and electronics for the mobile sector. The specific layout of hydraulic components has led to a significant increase of the reliability and availability of a mobile machine in numerous projects.

...designed to ensure **high power density** and **robustness**



MOBILE

APPLICATION EXAMPLES

- Brake systems and couplings
- Port crane control
- Construction machinery
- Forestry machinery
- Salt spreader vehicles
- Fan drives
- Machinery with lifting functions (forklift truck, lifting platform, etc.)

CHARACTERISTICS

- High volume flows
- Sensitive control characteristics
- Low hysteresis
- Low weight
- Robust construction
- Secure against vibrations and other external influences
- Hydraulically efficient valve technology
- Smart control by means of electronics developed in-house via a bus system
- Corrosion protection valves (up to stainless steel)
- Explosion protection valves including electronics
- Individual customer-specific adaptations
- Worldwide customer service



WANDFLUH OIL+GAS

Work involving highly explosive liquids and gases requires accordingly secured technology. Especially in the oil and gas exploration sectors but also in mines with high dust generation or gas influx, explosion protection is a hugely important issue. In order to carry out heavy work without risks in such hazardous areas, an explosion-protected valve technology was already developed and implemented years ago.

FOCUS

Apart from explosion protection, the requirements placed on valve technology in the oil and gas sector are extensive, since energy sources are often to be found either in very warm or in extremely cold areas in the world. With valves for ambient temperatures of down to -60 °C or up to +90 °C, a large temperature range can be covered. Explosion-proof valves are often also used outside in harsh environmental conditions. They not only come into contact with salt water but are also exposed to corrosive gases or substances. Explosion-protection valves are therefore mostly made from corrosion-resistant or stainless materials. Over decades, Wandfluh has developed a broad portfolio of valve and amplifier technology that has proven highly successful in numerous projects.

...designed to ensure **safety** and **reliability**



OIL+GAS

APPLICATION EXAMPLES

- Oil drilling head control
- Winch power control
- Flap control on oil and LNG tankers
- Process control
- Drilling vessels
- Compressor stations
- Gas separation
- Pipelines

CHARACTERISTICS

- Explosion-protection certification for various countries and regions
- High reliability
- Broad explosion-protection range of switching and proportional valves
- Corrosion-protection valves, from Zi/Ni through to stainless steel
- Redundant systems
- Valve technology with switching position monitoring
- Reduced electrical power
- Individual customer-specific adaptations
- Worldwide customer service



WANDFLUH MARINE

Wandfluh valves are increasingly being used in the marine sector. By using stainless materials or equivalent surface treatments, corrosion protection is guaranteed even in wet and salty conditions. When using water glycol as a hydraulic fluid, the inner workings of the valves are adapted accordingly.

FOCUS

The harsh conditions at sea require robust and proven technology that works reliably within a relatively high temperature range. In the marine sector, the Wandfluh portfolio focuses on corrosion and explosion protection valve technology with low leakage. The range of marine products additionally includes valves constructed specially for the underwater world which, thanks to their pressure compensation, are designed for underwater robots with diving depths of 6,000 m. These valves are often powered by biodegradable water glycol. On numerous projects, Wandfluh has collaborated closely with its customers to develop partial or complete solutions that meet the high demands of the sector and the customers.

...designed to ensure **corrosion protection** and **low leakage**



MARINE

APPLICATION EXAMPLES

- Ballast water management (actuation of ball valves and butterfly valves)
- Ship's hatch control
- Brake systems for winches
- Control of the manipulator arms of ROVs
- Thruster control in underwater robots
- Precise positioning with port cranes

CHARACTERISTICS

- Corrosion protection valves (up to stainless steel)
- Explosion protection valves including electronics
- Valve technology for high external pressure
- Valves for water glycol
- Valves with reduced leakage
- Anti-cavitation protection
- Smart control with electronics developed in-house via a bus system or directly on the valve
- Miniature valves
- Redundant systems
- Individual customer-specific adaptations
- Worldwide customer service



WANDFLUH ENERGY

Redundancy and switching safety combined with a long service life are the main characteristics of components used in the energy sector. The hydraulic switching circuits at the heart of these installations often are a part of the system-relevant and sometimes safety-critical control elements in power plants.

FOCUS

In energy plants, extremely high forces are bundled and controlled. Since the advent of hydropower, hydraulic control systems have been used for this. They regulate water supply, for example, and control the angles of turbine blades. In the wind energy sector, the position of the rotor blades angles are adjusted hydraulically in a similar way as with water turbines. In addition, hydraulic brake systems are used in wind power plants to decelerate the turbines in case of heavy winds to prevent any damage to the installations. In thermal power plants, a typical application is controlling butterfly valves, which reduce the steam pressure quickly and in a controlled way in the event of an emergency. In all of these applications, safety is the top priority. Frequently redundant systems with switching position monitoring are used here which can be precisely adapted to the relevant system together with the customer.

APPLICATION EXAMPLES

- Steam flap controllers
- Adjustment of the rotor blades of wind generators
- Control of disc brakes
- Turbine controllers
- Process control
- Butterfly valve control
- Continuous positioning of solar panels

...designed to ensure **extreme forces** and **a long service life**



ENERGY

CHARACTERISTICS

- Corrosion protection valves, from zinc-nickel through to stainless steel
- Redundant systems
- Valve technology with switching position monitoring
- Precise adaptation to a hydraulics system by means of electronics developed in-house and intelligent software
- Parametrisable controller electronics with bus connection (HART, Profibus, etc.)
- Sensitive control characteristics
- Precise proportional valves
- Reduced electrical power
- Ease of maintenance
- BlueCompetence products
- Individual customer-specific adaptations
- Worldwide customer service



BASIC SOLUTIONS

Wandfluh's specialist engineers have many years' experience of the world of hydraulics. As a competent partner, Wandfluh Systems is always ready to take on challenging projects with customers and develop innovative hydraulics and electronics solutions. The aim is to offer the optimal solution and the maximum added value for the project. The thousands of realised systems in both stationary and mobile hydraulics applications guarantee technically and economically optimised products.

CONCEPTION

The Wandfluh development department is home to highly qualified hydraulics and electronics engineers. They are available from the concept stage through to commissioning and work with state-of-the-art tools. This makes it possible to carry out flow simulations and to perfectly design hydraulic components on screen in advance. 3D models are made available at an early stage in order to simplify integration into the machine or installation. For each hydraulic system, a detailed documentation is produced.

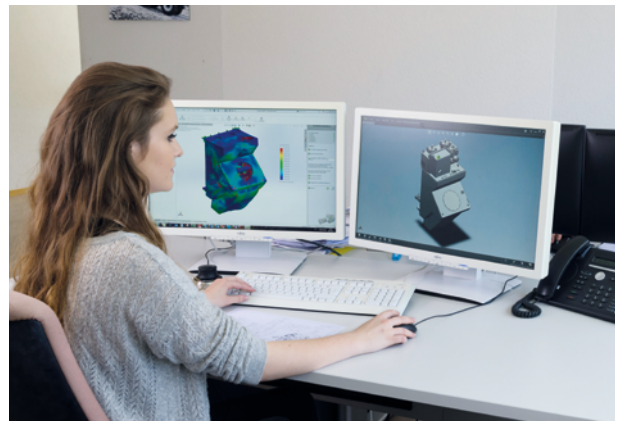

IMPLEMENTATION

All components are manufactured at the company's own production facilities in Frutigen. SWISS MADE in the highest quality is the Wandfluh standard. The assembly personnel have many years' experience in hydraulics and stand for impeccable function of the hydraulic system. Every valve manufactured, as well as every Wandfluh hydraulic power unit, undergoes rigorous inspection and testing at our test facilities. Delivery is only released when the inspection has 100% successful.

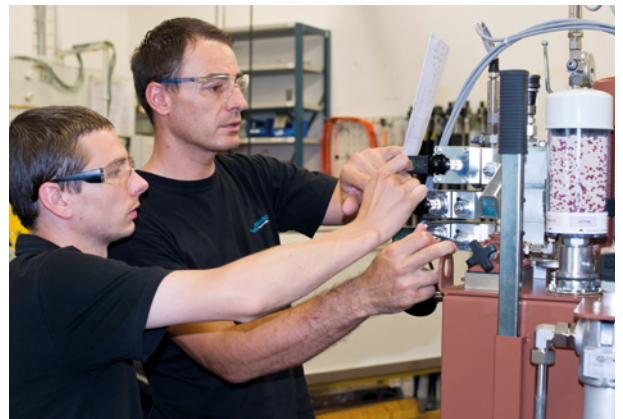

CUSTOMER SERVICE

Wandfluh Systems service engineers and technicians are there to help with installation and commissioning. Optimally equipped mobile workshops allow them professional work on site. In the event of any interferences, straight forward support is offered. The service team is also available for periodic maintenance work on Wandfluh hydraulic systems or those of different origin.



BASIC SYSTEMS

The term basic systems describes the basic modules with a modular control design and also serial power units. In a customer-specific design and construction, these are mainly used in industrial machinery. Both product types are manufactured in large numbers and at interesting prices.

BASIC MODULES

Wandfluh has launched a new line of energy-efficient power units. The big difference between these energy-efficient power units/basic modules and other commercially available hydraulic power units is the conception of the interface which for the customer-specific circuit set-up can either be arranged directly on the power unit, or in a decentral location. As a result, from a basic module and a customer-specific design, a system solution especially tailored to the customer's needs is realised.

In order to offer excellent functionality, energy efficiency, small space requirement, durability and reliability at low costs, a customer-specific hydraulic system is often designed using basic modules from the BM standard line.

The core element of the newly developed power unit/basic modules is an intelligent basic control unit with an integrated economy circuit. The design basically consists of an electric motor, a hydraulic pump, filter units, and a pressure accumulator. For the calculation and the development of the basic control unit and the choice of the electric motor, special attention is paid to energy efficiency.

UP TO 80% ENERGY SAVINGS THANK TO INTELLIGENT CIRCUITS

Due to the new, intelligent circuit diagram for the basic control unit, the motor operating time can be considerably reduced compared with the conventional accumulator unloading operation. This leads to significant energy savings of up to 80% during operation. In addition to the improved circuit diagram of the basic control unit, the basic modules can optionally be equipped with a process-controlled frequency converter which leads to a further substantial improvement of the energy balance.

CHN STANDARD POWER UNIT LINE

The proven CHN standard power unit line remains part of the programme. It is also available as a ATEX execution. With tank volumes of up to 60 l, a pump flow rate of up to 25.5 l/min, and motor power of up to 7.5 kW, these power units cover a wide range of applications.



SERIAL POWER UNITS

Wandfluh specialises in highly specific power units for machine tools. Special tanks are designed for installation situations with restricted space, control units and hydraulic circuits are adapted application-specifically to the machine. Apart from hydraulically controlled movements, lubrication functions are also controlled. Wandfluh power units are available in a power range from 0.25 to 55 kW, with tank sizes between 3 and 1,500 l.

SERIAL POWER UNIT FOR GRINDING MACHINES

Customer-specific serial power units for grinding machines. The hydraulic power unit has a separate lubrication circuit with a maximum pressure of 1 bar and also a high-pressure circuit for the oil supply of the hydraulic functions such as clamping, tensioning, or moving dressers.



SERIAL POWER UNIT FOR MACHINING CENTRES

Customer-specific serial power unit for a compact 5-axis machining centre. The machining centre is particularly used in the watch industry. As a result, fully comprehensive extreme precision was required. The hydraulic control is designed to be decentralised. The tank with the pressure supply is located separately from the control unit.

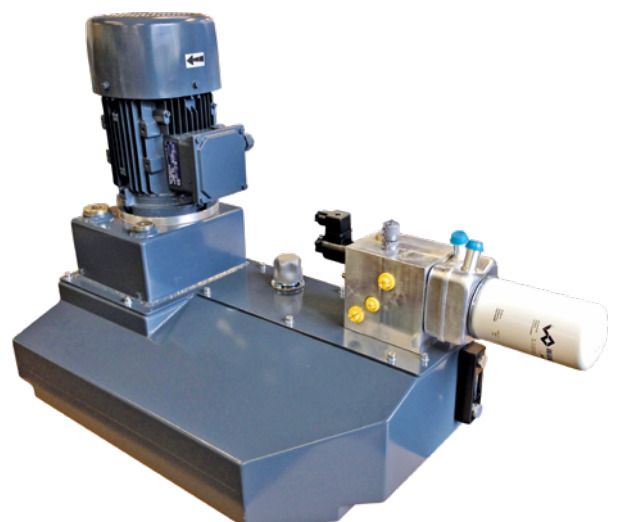

STANDARD POWER UNITS

Wandfluh Systems is launching an innovative line of products in the construction of power units. It involves a combination between a basic module and a hydraulic circuit precisely adapted to the customer's requirements. With the intelligent circuit diagram of the

BM-COMPACT4 STANDARD POWER UNIT

The BM-Compact4 power unit is often used for tensioning or clamping functions in milling machines. Due to its cost-optimised and compact construction it is suited for a wide variety of machine types.

Tank volume	6.3 l
Motor power	0.18 ... 0.75 kW
Pump flow rate	Up to 2.8 l/min
Basic control unit	Compact NG4
Filtration	6µm
Spin-on return filter	



BM-COMPACT6 STANDARD POWER UNIT

The BM-Compact6 power unit is often used for quick tensioning or clamping functions in machine tools. Due to its cost-optimised and compact construction it is suited for a wide variety of machine types.

Tank volume	10.0 l
Motor power	0.25 ... 1.5 kW
Pump flow rate	Up to 10.0 l/min
Basic control unit	Choice of NG4 or NG6
Filtration	6µm
Spin-on return filter	



basic block there is a clear reduction in the operating time of the motor compared to the conventional accumulator unloading operation. This results in a significant energy saving of up to 80% during the operation.

BM-FLEX6 STANDARD POWER UNIT

The BM-Flex6 power unit can be used with great flexibility in a wide variety of machine tools. This is ultimately a 10 l power unit on which a suitably large accumulator can be mounted.

Tank volume	10.0 l
Motor power	0.25 ... 1.5 kW
Pump flow rate	Up to 10.0 l/min
Basic control unit	Choice of NG4 or NG6
Filtration	6µm
Spin-on return filter	



BM-REFORM6/F STANDARD POWER UNIT

The BM-Reform6/F power unit is used in machine tools with very demanding criteria regarding functionality and energy efficiency. In order to achieve the highest possible energy efficiency, it can be optionally equipped with a frequency converter which is mounted directly on the motor and which offers full Industry 4.0 conformity. To ensure the highest oil purity for critical applications, a pressure filter can also be mounted.

Tank volume	25.0 l
Motor power	0.25 ... 1.5 kW
Pump flow rate	Up to 19.0 l/min
Basic control unit	Choice of Reform NG6 or Flex NG6
Filtration	6µm
Pressure or return filter	



CONTROL UNITS

Specialised Wandfluh engineers with many years of experience in a wide variety of branches develop control units that are perfectly designed for the respective functions. Intelligent circuits are combined with compact construction and high quality components.

OIL+GAS

Control unit for unloading systems of gas tankers. Highest demands with respect to explosion protection and manual overrides for all safety relevant functions are fulfilled. Small space conditions ask for an extremely compact construction of the complex hydraulic control.

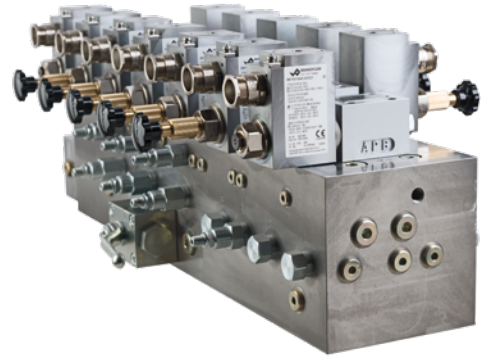

MOBILE

Control units in large quantities for the safety function of a priority circuit on agricultural machines. The safety aspect and reliability are at the forefront of this development.



INDUSTRY

Control unit NG10 for fast and highly precise movements of sheet metal bending machines.

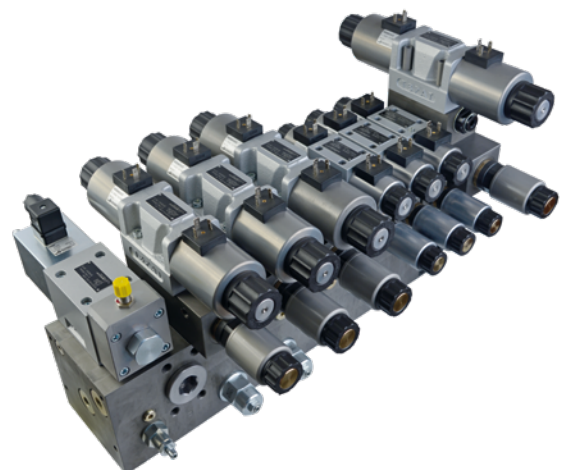

COMPLETE SOLUTIONS

Already at the beginning of the planning phase, Wandfluh as a specialist provider of large hydraulic power units and systems offers optimal advice. Due to its many years of experience, cost-optimised and technically outstanding solutions are realised.

CONSULTATION

Specialist Wandfluh engineers with years of experience accompany the implementation of complete electro-hydraulic systems from A to Z. A competent partner, Wandfluh Systems is always ready, in partnership with the customer, to tackle new, challenging projects and develop innovative hydraulic and electronic solutions. The aim is to offer the optimal solution and the maximum added value for the project. The hundreds of realised systems, both in Switzerland and abroad, guarantee technically and economically optimised solutions.

DESIGN

Wandfluh's experienced engineers and technicians are available for elaborating the specifications for the installation project.

DEVELOPMENT, CONSTRUCTION

If required, the conception of the entire system is taken over, from the hydraulic power unit to the control units, from any special cylinder to the definition of electrical interfaces and the electrical control cabinet.

IMPLEMENTATION, MANUFACTURE

The central elements of a hydraulic power unit are the hydraulic valves and control units. These are manufactured at the Wandfluh factory in Frutigen. For the construction of the system as a whole, only high-quality products from carefully selected suppliers are considered.

INSTALLATION, TESTING, COMMISSIONING

Construction work and factory testing for all Wandfluh hydraulic power units take place at the company's own modern facilities. If the hydraulic system needs to undergo very thorough testing during acceptance at the factory, Wandfluh offers a realistic simulation set-up.

CUSTOMER SERVICE, AFTER SALES SERVICE

Wandfluh Systems service engineers and technicians are there to help with installation and commissioning. Optimally equipped mobile workshops allow them professional work on site. In the event of any interferences, straight forward support is offered. The service team is also available for periodic maintenance work on Wandfluh hydraulic systems or those of different origin.

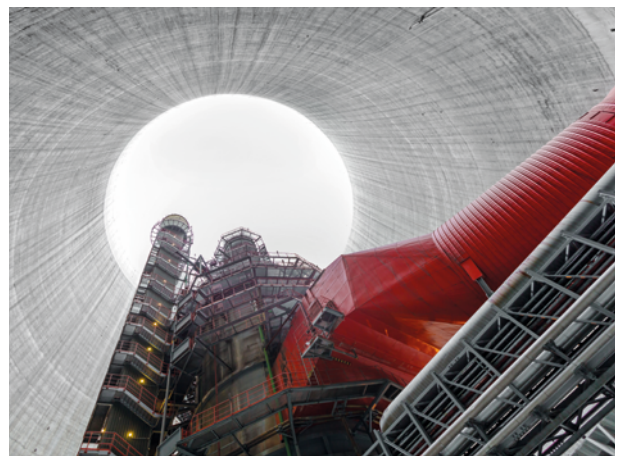

LARGE SYSTEMS

Hydraulic systems and power units are not only used in large series as is typically the case with construction machinery or in industry. Thanks to their reliable and durable technology, they are also used in individual projects to control powerful forces.

HYDRAULIC TURBINE CONTROLLER

Hydraulic Francis turbine controller for continuous operation, 24h / 365 days a year. Redundant pump circuits make it possible to exchange pump units as well as filter elements during running operation. The hydraulic control element is mounted on a 600 l tank and a stainless collecting tray. All electrical consumers are wired to a terminal box. The innovative and energy-efficient concept with variable displacement pumps and accumulator elements is combined with a very compact construction.



HYDRAULIC POWER UNIT FOR WATER CATCHMENT

The hydraulic power unit for water catchment controls inlet and outlet gates, de-sanders and other shut-off devices of the water catchment in a power station. Given the harsh environmental conditions at altitudes of more than 2000 m, all pipes and sheet metal parts are made of stainless steel. With their special surface coatings, all hydraulic valves meet higher corrosion protection requirements. A pressure accumulator provides the energy to ensure continuous water catchment operation also in the event of temporary power failures. All electrical signals are wired to a control cabinet, so that a complete signal test can be performed already at the manufacturer's factory to ensure an efficient installation in high altitude mountains.

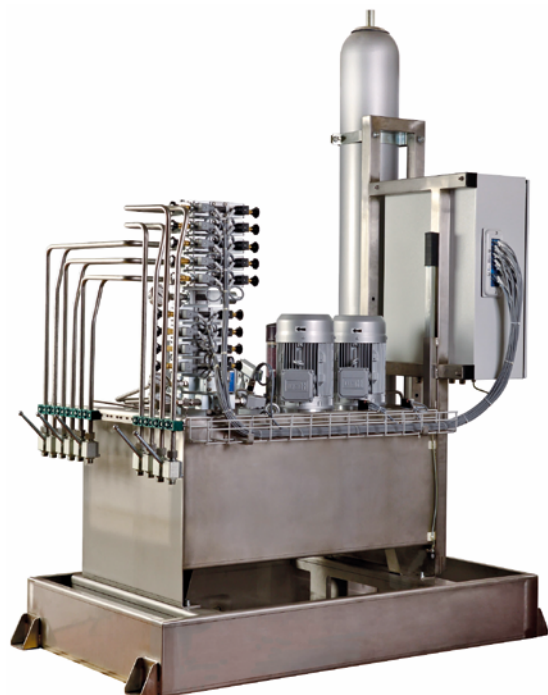

Wandfluh power units are available in a power range from 0.25 to 55 kW, with tank sizes between 3 and 1500 l. Here are a few examples of projects implemented in close collaboration with customers.

EXPLOSION SAFE HYDRAULIC POWER UNIT FOR USE UNDER AND OVER WATER

The hydraulic power unit controls the safe decoupling of the buoy of an FPSO Unit (Floating Production Storage and Offloading Unit), i.e. a floating oil platform. The use of the power unit both, in an explosive environment over water as well as immersed in up to 20 m under water, requires the highest demands for explosion protection, corrosion protection as well as compliance with all the standards required in this case.



HYDRAULIC POWER UNIT TO CONTROL BUTTERFLY VALVES

The hydraulic power unit for controlling butterfly valves is mounted on a 160 l tank and a stainless collecting tray. The tank and the oil collecting tray are painted in the colours specified by the customer. The display instruments showing oil and water pressures are clearly arranged on a panel. A switchable double pressure filter enables filter elements to be replaced during running operation. Intelligent layout and arrangement of the components made it possible to build a very compact power unit.



SPOOL VALVES

Spool valves are primarily used to control the direction of movement and to move hydraulic cylinders and motors. To realise a high availability of such a hydraulic circuit, the switching power and possible leakage of the valves must be already taken into account when the system is designed. Solenoid spool valves are suitable for machine tools and all types of mobile handling systems.

CHARACTERISTICS

- Precise spool fit
- Low leakage

EXECUTIONS

- Direct or pilot operated
- Detented, spring centred or with spring reset
- Proportional functions

ACTUATIONS

- Solenoid actuated by means of switching solenoid
- Solenoid actuated by means of proportional solenoid
- Proportional electronics integrated into the valve
- Manually actuated by means of hand lever
- Mechanically actuated by means of roller
- Pneumatically actuated
- Hydraulically actuated

OPTIONS

- Special spool
- Soft-switching execution
- Enhanced corrosion protection
- Special spool play for low leakage
- Sandwich execution
- Explosion protection
- Switching position monitoring
- Various types of electrical connections
- Special voltages
- Electrical low power

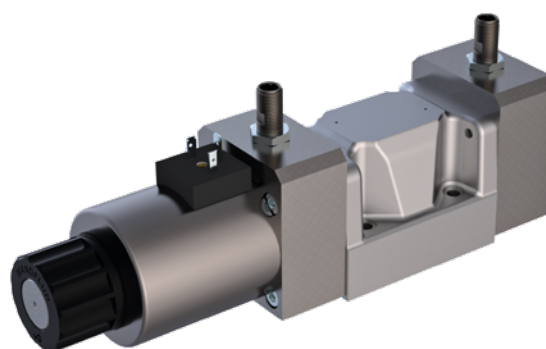

With double switching position monitoring

FLANGE	NG3	NG4	NG6	NG10
Qmax [l/min]	15	30	80	160
Pmax [bar]	350	350	350/420	350

CARTRIDGE	U08	U10
Qmax [l/min]	23	28
Pmax [bar]	350	350

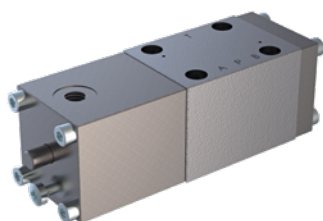

Pneumatically actuation

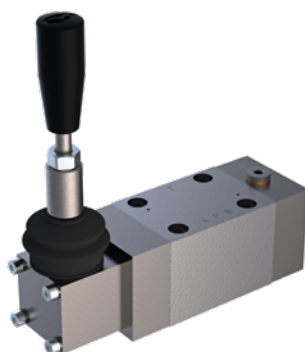

Manual actuation



Cartridge execution

POPPET VALVES

Poppet valves are used where tight closing functions are essential like leakfree holding of loads, clamping or gripping. Depending on the execution, the poppet valve spool can be opened or closed with a switching solenoid or by the opposite spring. Poppet valves are used in all branches in different executions.

CHARACTERISTICS

- Excellent durable tightness seal as a result of metallic sealing seat
- Poppet design with equal surface areas and pressure balanced on both sides
- Seal tight in all directions of flow
- Cartridge, flange and sandwich construction

EXECUTIONS

- Direct or pilot operated
- Detented, spring centred or with spring reset
- 2/2- and 3/2-way executions

ACTUATIONS

- Solenoid actuated by means of switching solenoid
- Manually actuated by means of hand lever
- Pneumatically actuated

OPTIONS

- Special symbols
- Soft-switching execution
- Enhanced corrosion protection
- Special actuations
- Explosion protection
- Switching position monitoring
- Detented execution
- Various electrical connections
- Special voltages
- Power reducing plug

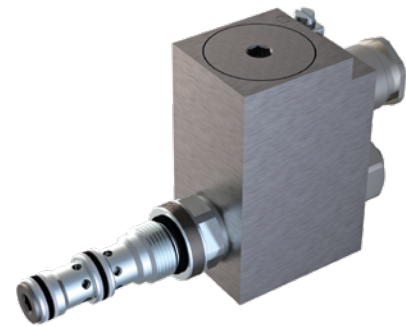

Ex-protection

FLANGE	NG3	NG4	NG6	NG10
Qmax [l/min]	6	15	40	80
Pmax [bar]	350	350	350	350

CARTRIDGE	M18/U08	M22/U10	M33	M42
Qmax [l/min]	50	80	150	300
Pmax [bar]	350	350/420	350	350

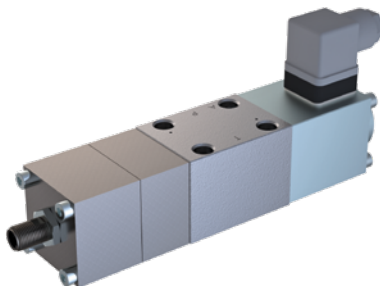

Switching position monitoring



Manual actuation

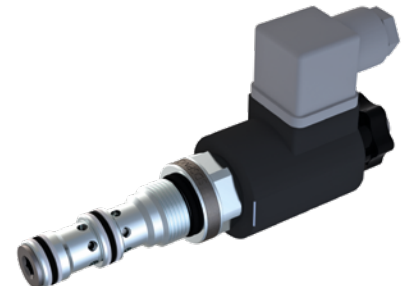

Cartridge execution

PRESSURE VALVES

Practically all hydraulic systems require some form of pressure valve, whether it is to secure the system with a pressure relief valve against overpressure in order to avoid damage, or to supply a part of the hydraulic system by means of a pressure control valve with lower pressure. With a sequence valve, a user can be connected on as soon as an adjusted pressure is reached. Pressure valves are used in all branches and applications in various executions.

CHARACTERISTICS

- Excellent longevity due to hardened and ground spools and sleeves
- Cartridge, flange and sandwich execution

EXECUTIONS

- Pressure relief valve
- Pressure reducing valve
- Proportional functions
- Sequence valve
- Accumulator loading/unloading function
- Pressure protection for accumulator
- Direct or pilot operated
- Seat tight executions

ACTUATIONS

- Manual
- Electrical
- Proportional
- Proportional electronics integrated into the valve

OPTIONS

- Explosion protection
- Enhanced corrosion protection
- Actuation protection
- Various electrical connections

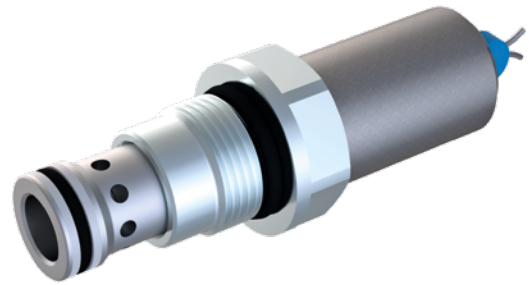

Safety valve

SANDWICH	NG3	NG4	NG6	NG10
Q_{max} [l/min]	8	30	80	100
P_{max} [bar]	350	350	350	350

CARTRIDGE	M18/U08	M22/U10	M33	M42
Q_{max} [l/min]	30	100	230	400
P_{max} [bar]	400	450	350	350

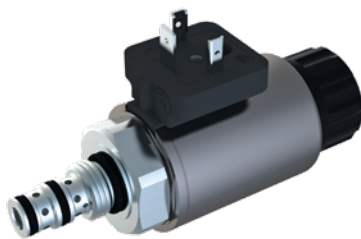

Cartridge execution

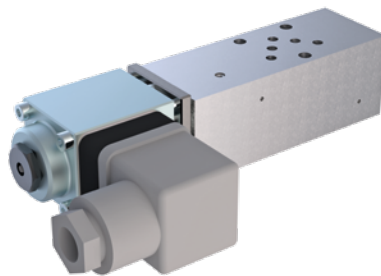

Flange/sandwich execution

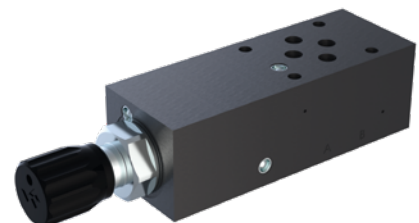

Manual actuation

FLOW VALVES

Flow valves are used to control the amount of oil flow. Throttle valves change the opening cross-section and thereby influence the amount of oil and therefore the speed of the cylinder. Flow control valves in contrast to throttle valves are equipped with additional pressure compensation. Consequently, the adjusted volume flow remains unchanged even in case of a variable load pressure. This leads to a uniform and load-independent movement of a cylinder.

CHARACTERISTICS

- Excellent longevity due to hardened and ground spools and sleeves
- Cartridge, flange and sandwich execution

EXECUTIONS

- Throttle function
- Flow control valve 2- and 3-way
- Proportional functions
- Load compensation
- Direct or pilot operated

ACTUATIONS

- Manual
- Electrical
- Proportional
- Proportional electronics integrated into the valve

OPTIONS

- Explosion protection
- Enhanced corrosion protection
- Actuation protection
- Various electrical connections

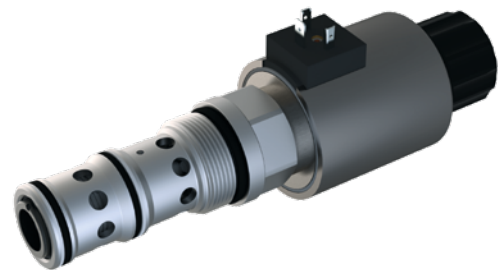

Cartridge execution

SANDWICH	NG3	NG4	NG6	NG10
Q_{max} [l/min]	15	20	80	100
P_{max} [bar]	350	350	350	350

CARTRIDGE	M18	M22	M33/U16	M42
Q_{max} [l/min]	30	60	140	200
P_{max} [bar]	350	350	350	350



All-in-one

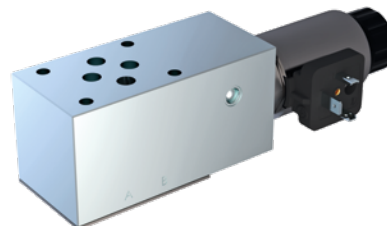

Flange/sandwich execution

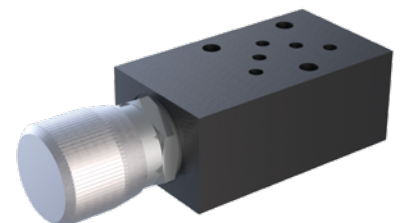

Manual actuation

CONTROL ELECTRONICS

For the control of proportional valves, electronic control devices are required. They control the solenoid current on the valve and thus guarantee a highly sensitive, low-hysteresis valve control by means of Pulse Width Modulation and a superimposed dither signal.

The control devices are equipped with a microprocessor. This extends the functionality and flexible utilisation in a control system. The various electronic devices offer amplifier

CHARACTERISTICS

- High operating comfort
- Easy handling
- High functionality as a standard
- Support of all current, voltage and frequency signals
- Linear ramp functions
- Fixed command values
- Programmable travel profiles
- Expandable as per customer-specific requirements
- Fieldbus interfaces CAN, Profibus

FUNCTIONS

- Digital amplifiers with high quality solenoid current controllers
- Digital 1-axis and 2-axis controllers
- Position controllers
- Force limiting position controller
- Pressure controllers
- Flow controllers
- Various fieldbus interfaces
- Freely programmable (PME)
- Display and keyboard

CONSTRUCTION

- Connector execution
- Snap-on modules
- Mobile execution
- Integrated into the valves (DSV)



Amplifier/controller module Industry



Amplifier/controller module mobile



Programmable display



Amplifier electronics

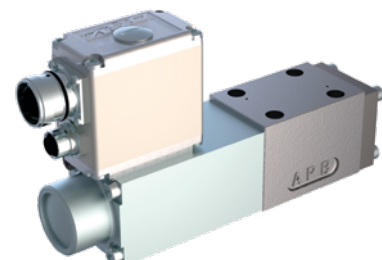

Integrated Electronics

and controller functions with an optional field bus interface to provide a simple connection to superordinate control systems. The electronic devices are very easy to use. For the adjustment of the different parameters and the diagnosis when setting up or in the case of maintenance, a parameterisation software is available which graphically displays the possible functions and provides the user with numerous tools for analysing and adjusting the device.

PARAMETERISATION AND PROGRAMMING

- PC software PASO (freely available)
- Process data display
- Integrated oscilloscope
- Remote control functions
- Support of fieldbus
- Individual process data monitor
- Universally usable for all control devices
- Communication with control device via USB

ADDITIONAL EXECUTIONS

- Customer-specific software expansions
- Hardware expansion for additional functions
- Software for solutions optimized with respect to application
- Flexible interface definition
- Electronics integrated into the valve

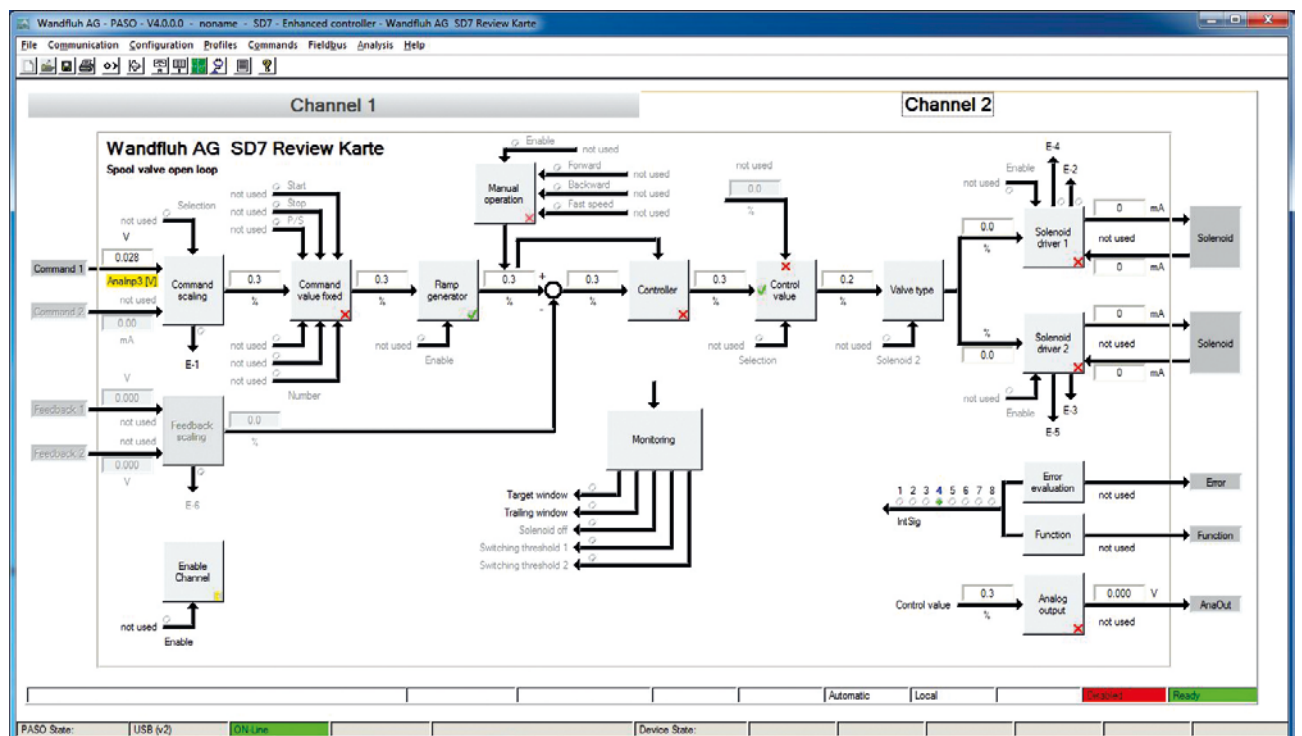
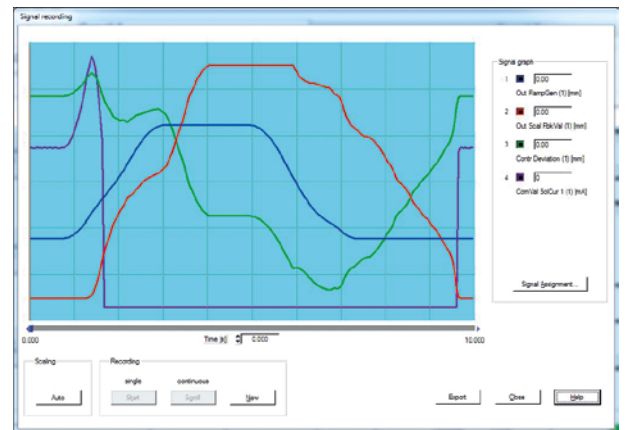

SWITZERLAND

Wandfluh AG Division Systems

Helkenstrasse 13
3714 Frutigen
Tel. +41 33 672 72 52
Fax +41 33 672 72 87
sales-ch@wandfluh.com
www.wandfluh.com

SWITZERLAND

Wandfluh Produktions AG

Parallelstrasse 42
3714 Frutigen
Tel. +41 33 672 73 73
Fax +41 33 672 73 93
wapro@wandfluh.com
www.wapro.ch

GERMANY

Wandfluh GmbH

Friedrich-Wöhler-Strasse 12
78576 Emmingen
Tel. +49 74 65 92 74 0
Fax +49 74 65 92 74 20
info@wandfluh.de
www.wandfluh.de

AUSTRIA

Wandfluh GmbH

Färbergasse 15
6850 Dornbirn
Tel. +43 55 72 38 62 72 0
office-at@wandfluh.com
www.wandfluh.at

FRANCE

Wandfluh SARL

Parc Technologique
Immeuble le Pôle
333, Cours du Troisième Millénaire
69791 Saint-Priest Cedex
Tel. +33 4 72 79 01 19
Fax +33 4 13 57 02 41
contact@wandfluh.fr
www.wandfluh.fr

UNITED KINGDOM

Wandfluh UK Ltd.

Northfield Road
Southam CV47 0FG
Tel. +44 1 926 81 00 81
Fax +44 1 926 81 00 66
sales@wandfluh.co.uk
www.wandfluh.co.uk



CHINA

Wandfluh (Shanghai) Hydraulic System Co. Ltd.

No. 450 Beihengshahe Road
Minhang District
Shanghai 201 108
Tel. +86 21 67 68 12 16
Fax +86 21 67 86 12 18
sales@wandfluh.com.cn
www.wandfluh.com.cn

AMERICA

Wandfluh of America, Inc.

909 High Street
Mundelein, IL 60060, USA
Tel. +1 847 566 57 00
Fax +1 847 566 57 33
sales@wandfluh-us.com
www.wandfluh-us.com

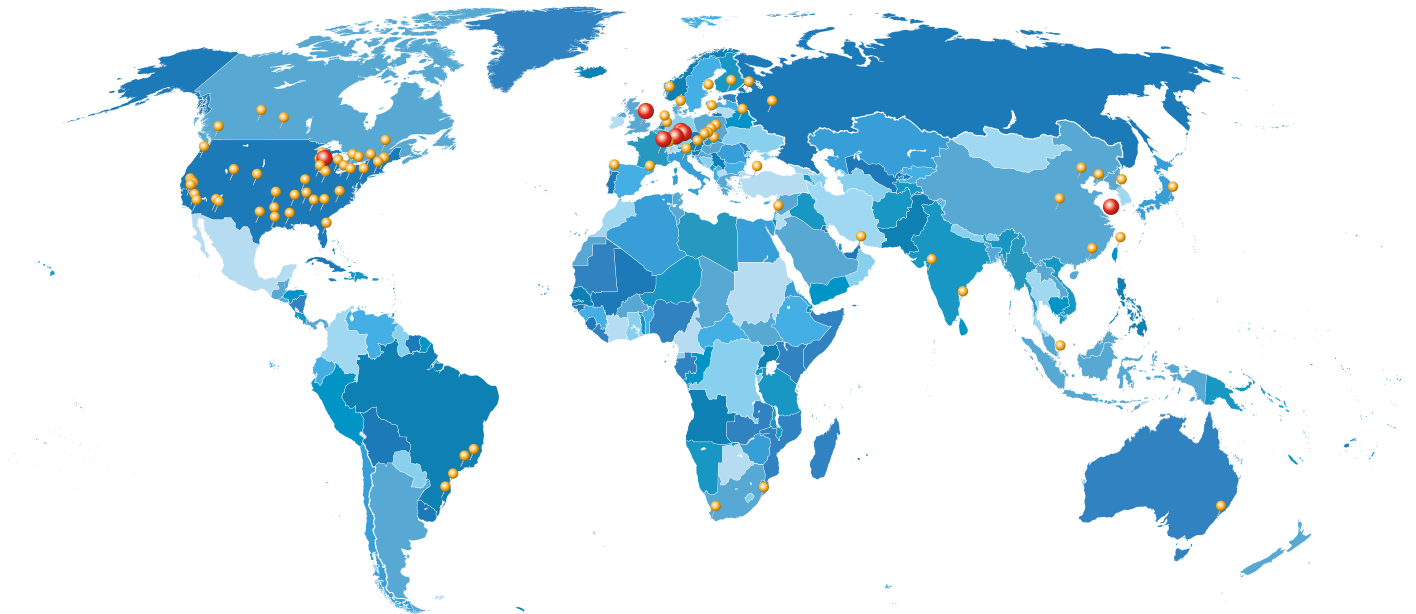

SOLUTIONS SINCE 1946